



First Data Solutions
featuring **Clover Station**

First Data®

First Data Solutions with Clover Station A Whole New World of Business Management

You've worked hard to get your business going. Isn't it time you gave it – and yourself – an advantage? Now you can, with Clover Station

From managing employees and inventory to serving customers and marketing your business, you've got a lot going on. Clover Station lightens the load with advanced software that will have you up, running and in the lead in no time.

Clover Station is a powerful business management system that works the way you need it to. Built on the most sophisticated software platform of its kind, it offers unparalleled flexibility and convenience. More importantly, it's easy to use – for you and your customers.

Ohio

Department
of Commerce
Division of Liquor Control

Liquor Modernization Project

Accurate | Reliable | Useful

Do a lot more, a lot more efficiently

Running a business typically means you're doing more than one thing at a time. It also means you can't afford to let critical functions slip through the cracks. With Clover Station, that's one less worry you'll have. It's a complete business management system that helps everything stay on track, so you can focus on the fun stuff.

Clover Station is intuitive and easy to use. Right out of the box, you'll be able to:

- Accept more types of payments from magnetic stripe and EMV[®] credit and debit cards to Apple Pay[™] without additional equipment or complicated software
- Protect your customers, business and reputation from fraud with built-in Clover Security
- Configured out of the box to interface with the Ohio Liquor Enterprise for sales submission and pricing updates
- Concierge service and technical support will be covered by the Ohio Liquor Enterprise for two years
- Manage returns, inventory and even employees with advanced software and unique apps designed to help you customize your system

Clover Station runs on cloud-based software so you can access your business information wherever you are, from a computer, tablet or mobile phone. And, as you grow, you can enhance and customize your system with apps from the fast-growing Clover App Market.



Want to make your business all that it can be?
Clover Station makes it possible.



The Ohio Liquor Enterprise has negotiated a **custom merchant service program**, which includes reduced fees, for Contract Liquor Agencies. To learn more about this custom program, email emily.ebright@firstdata.com.

Learn more:

If you have questions about the retail terminal strategy in general or need assistance, please contact the DOLC Help Desk – 24 hours a day, seven days a week

877-812-0013

liquoragencyhelp@com.state.oh.us

Or visit <https://liqagency.com.ohio.gov/LMP2>

Clover Station : Beautiful Outside

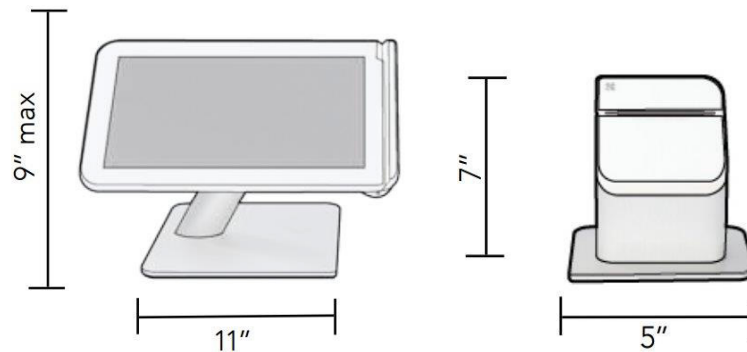

Touchscreen + Card Reader

- Brushed aluminum touchscreen display with white glass accents
- 11.6" high resolution touchscreen attached to a 11"x7.5" base plate
- Maximum height from countertop to display top 9"
- 3.5mm audio jack for talk-to-text / ADA compliance
- Encrypted card swiper built into touchscreen display
- Fast focusing camera for barcode and QR code scanning

Receipt Printer

- Quick speed thermal receipt printer (6.89" x 6.89" x 6.94")
- Four USB ports smartly hidden under the thermal printer for peripheral expansion
- Coordinated cash drawer (16.54" x 16.54" x 4.25")

General Hardware

- Patent-pending swivel arm rotates screen 180° from landscape (merchant view) to portrait (happy customer view)
- Ethernet and WiFi enabled
- Single power source for display, thermal printer, and cash drawer
- Optional peripherals such as kitchen printers, hand held barcode scanner and integrated weight scale



Department
of Commerce

Division of Liquor Control

Liquor Modernization Project

Accurate | Reliable | Useful

First Data.
Powered

©First Data Corporation. All Rights Reserved. The FIRST DATA name and related trademarks and service marks are owned by First Data Corporation and are registered or used in the U.S. and many foreign countries. The CLOVER marks are owned by Clover Network, Inc., a fully owned subsidiary of First Data Corporation, and are registered or used in the U.S. and many foreign countries. All trademarks, service marks, and trade names referenced in this material are the property of their respective owners.